

AM33: The FleetTwo Dock

Adam Megacz

December 19, 2008

Abstract

Changes:

- 19-Dec Updated diagram in section 3 to put dispatch path near MSB
Changed DP[37:25] to DP[37:27]
Added note on page 4 regarding previous
- 14-Nov Roll back “Distinguish Z-flag from OLC=0”
Clarify what “X-Extended” means
Change C-bit source selector from Di to Dc
- 07-Nov Distinguish Z-flag from OLC=0
Add flush instruction
Change I bit from “Interruptable” to “Immune”
- 20-Sep Update hatch description to match IES50
- 28-Aug Note that decision to requeue is based on value of OLC *before* execution
Note that decision to open the hatch is based on value of OS bit
- 10-Jul Added OLC=0 predicate
Eliminated TAPL (made possible by previous change)
Expanded set Immediate field from 13 bits to 14 bits (made possible by previous change)
- 09-Jul Fixed a few typos
Added DataLatch → TAPL (Amir’s request)
Eliminate ability to predicate directly on C-flag (Ivan’s request)
- 16-Jun When a torpedo strikes, ILC is set to 1
Only move can be torpedoed (removed I-bit from set/shift)
- 11-Jun Changed all uses of “Payload” to “Immediate” (not in red)
Reworked encoding of set instruction
- 06-Jun Factored in Russell Kao’s comments (thanks!)
Added mechanism for setting C-flag from fabric even on outboxes

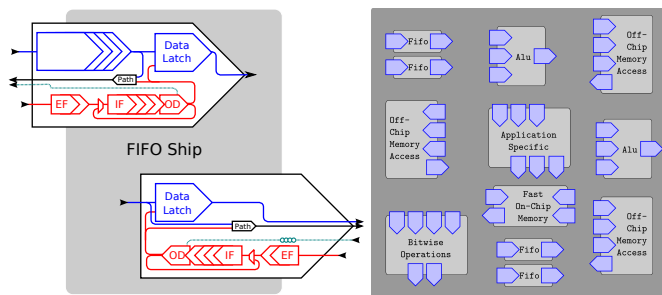

1 Overview of Fleet

A Fleet processor is organized around a *switch fabric*, which is a packet-switched network with reliable in-order delivery. The switch fabric is used to carry data between different functional units, called *ships*. Each ship is connected to the switch fabric by one or more programmable elements known as *docks*.

A *path* specifies a route through the switch fabric from a particular *source* to a particular *destination*. The combination of a path and a single word to be delivered is called a *packet*. The switch fabric carries packets from their sources to their destinations. Each dock has two destinations: one for *instructions* and one for *data*. A Fleet is programmed by depositing instruction packets into the switch fabric with paths that will lead them to instruction destinations of the docks at which they are to execute.

When a packet arrives at the instruction destination of a dock, it is enqueued for execution. Before the instruction executes, it may cause the dock to wait for a packet to arrive at the dock's data destination or for a value to be presented by the ship. When an instruction executes it may consume this data and may present a data value to the ship or transmit a packet.

When an instruction sends a packet into the switch fabric, it may specify that the payload of the packet is irrelevant. Such packets are known as *tokens*, and consume less energy than data packets.

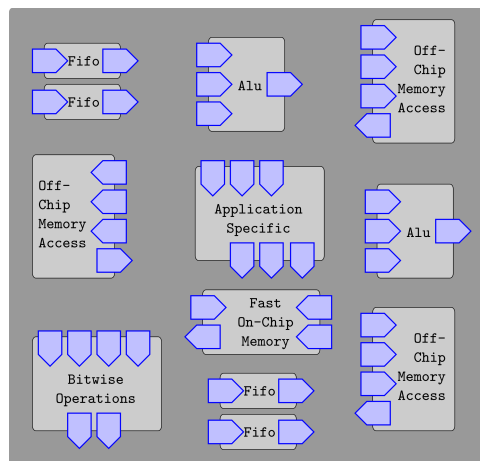

Overview of a Fleet processor; dark gray shading represents the switch fabric, ships are shown in light gray, and docks are shown in blue.

2 The FleetTwo Dock

The diagram below represents a conceptual view of the interface between ships and the switch fabric; actual implementation circuitry may differ.

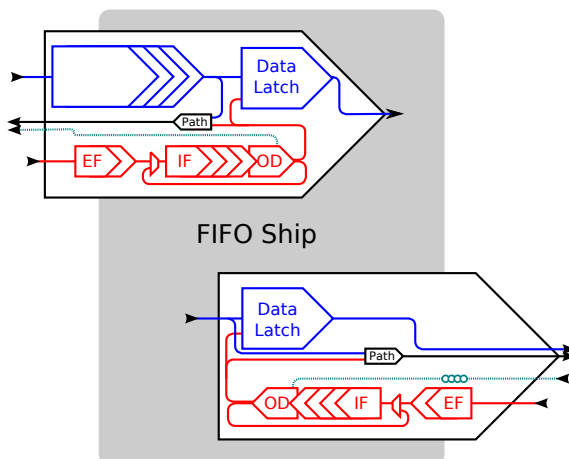

An “input” dock and “output” dock connected to a ship. Solid blue lines carry either tokens or data words, red lines carry either instructions or torpedoes, and dashed lines carry only tokens.

Each dock consists of a *data latch*, which is as wide as a single machine word and a *pump*, which is a circular fifo of instruction-width latches. The values in the pump control the data latch. The dock also includes a *path latch*, which stores the path along which outgoing packets will be sent.

Note that the pump in each dock has a destination of its own; this is the *instruction destination* mentioned in the previous section.

From any source to any dock’s data destination there are two distinct paths which differ by a single bit. This bit is known as the “signal” bit, and the routing of a packet is not affected by it; the signal bit is used to pass control values between docks. Note that paths terminating at an *instruction destination* need not have a signal bit.

3 Instructions

In order to cause an instruction to execute, the programmer must first arrange for that instruction word to arrive in the data latch of some output dock. For example, this might be the “data read” output dock of the memory access ship or the output of a fifo ship. Once an instruction has arrived at this output dock, it is *dispatched* by sending it to the *instruction port* of the dock at which it is to execute.

Each instruction is 26 bits long, which makes it possible for an instruction and an 11-bit path to fit in a single word of memory. This path is the path from the *dispatching* dock to the *executing* dock.



Note that the 11 bit *dispatch path* field is not the same width as the 13 bit *Immediate path* field in the *move instruction*, which in turn may not be the same width as the actual path latches in the switch fabric.

The algorithm for expanding a path to a wider width is specific to the switch fabric implementation, and is not specified by this document.¹ In particular, because the *dispatch path* field is always used to specify a path which terminates at an instruction destination (never a data destination), and because instruction destinations ignore the signal bit, certain optimizations may be possible.

3.1 Life Cycle of an Instruction

The diagram below shows an input dock for purposes of illustration:

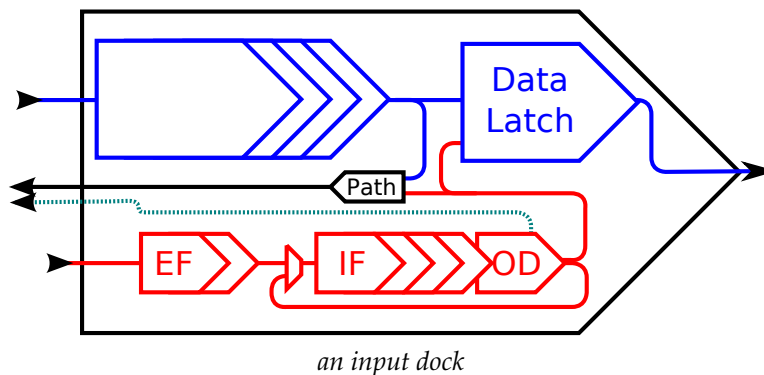

¹for the Marina experiment, the correct algorithm is to sign-extend the path; the most significant bit of the given path is used to fill all vacant bits of the latch

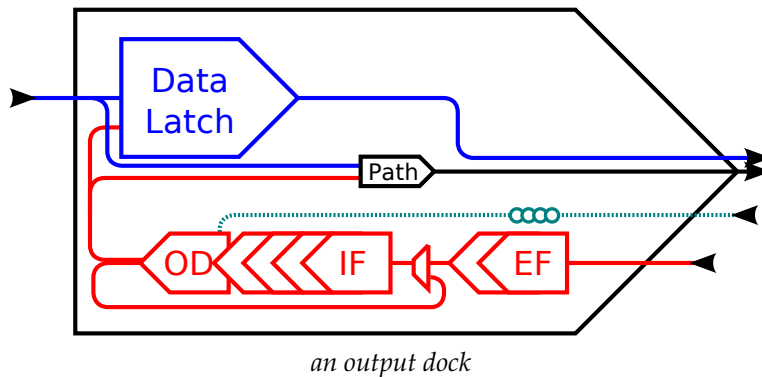

3.1.1 Torpedoes

A token sent to an instruction destination is called a *torpedo*. When a torpedo arrives at the tail of EF, it is deposited in a waiting area (not shown) rather than being enqueued into EF.

3.2 Format of an Instruction

All instruction words have the following format:

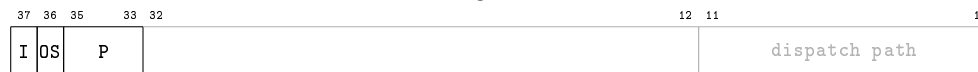

- The I bit stands for *Immune*, and indicates if an instruction is immune to torpedoes. This bit only appears in move instructions.
- The OS (“One Shot”) bit indicates whether or not this instruction can pass through the pump more than once. If set to 1, then the instruction is a “one-shot” instruction, and does not pass through the instruction fifo more than once.
- The P bits are a *predicate*; this holds a code which indicates if the instruction should be executed or ignored depending on the state of flags in the dock.

3.3 Loop Counters

A programmer can perform two types of loops: *inner* loops of only one instruction and *outer* loops of multiple instructions. Inner loops may be nested within an outer loop, but no other nesting of loops is allowed.

The dock has two loop counters, one for each kind of loop:

- OLC is the Outer Loop Counter
- ILC is the Inner Loop Counter

The OLC applies to all instructions and can hold integers 0 . . MAX_OLC.

The ILC applies only to move instructions and can hold integers 0 . . MAX_ILC as well as a special value: ∞ . When ILC=0 the next move instruction executes zero times (ie is ignored). When ILC= ∞ the next move instruction executes until interrupted by a torpedo. After every move instruction the ILC is reset to 1 (note that it is reset to 1, *not to 0*).

3.4 Flags and Predication

The pump has four flags: A, B, C, and Z.

- The A and B flags are general-purpose flags which may be set and cleared by the programmer.
- The C flag is known as the *control* flag, and may be set by the move instruction based on information from the ship or from an inbound packet. See the move instruction for further details.
- The Z flag is known as the *zero* flag; it is set whenever the OLC is zero, and is cleared whenever the OLC is nonzero.

The P field specifies a three-bit *predicate*. The predicate determines which conditions must be true in order for the instruction to execute; if it is not executed, it is simply *ignored*. The table below shows what conditions must be true in order for an instruction to execute:

Code	Execute if
000:	Z=0 and A=0
001:	Z=0 and A=1
010:	Z=0 and B=0
011:	Z=0 and B=1
100:	Unused
101:	Z=1
110:	Z=0
111:	always

3.5 The Hatch

What follows is a conservative approximation of the actual behavior of the hatch. For complete details on the behavior of the hatch, see [IES50](#).

For the purposes of this section, instructions will be classified into three categories: one-shot instructions ($OS=1$), requeueable instructions ($OS=0$), and tail instructions.

To avoid deadlock, the programmer must ensure that:

- A requeueable instruction is never followed immediately by a one-shot.
- A one-shot instruction is never followed immediately by a tail.
- No contiguous sequence of requeueable instructions is longer than the length of the instruction fifo.
- If a requeueable instruction is preceded by a one-shot instruction or a tail, then it must be the case that $Z=0$ both before and after the first time that instruction executes.
- If $Z=1$, only a one-shot instruction may set it to a nonzero value.

The dock guarantees that:

- If a requeueable instruction is preceded by a one-shot instruction or a tail, then the *following* instruction will not execute until a tail has reached the hatch.
- Once a tail instruction reaches the hatch, no further instructions will be enqueued until a requeueable instruction reaches the execution stage and $Z=1$.

3.6 On Deck

When an instruction arrives on deck, two concurrent processes are started:

1. Requeueing:
 - If the instruction on deck is a requeueable instruction ($OS=0$) and $Z=0$, a copy of the instruction is requeued.
2. Execution:
 - If the instruction's predicate condition is not met (see section on predicates), do nothing.
 - *Otherwise* if the instruction is interruptible ($I=0$) and a torpedo is present in the waiting area: consume the torpedo, set $OLC=0$, $Z=1$ and set the inner loop counter to one ($ILC=1$).
 - *Otherwise* if $ILC \neq 0$ or the instruction is *not* a move: execute the instruction.

4.2 set

The set command is used to set or decrement the inner loop counter, outer loop counter, and data latch.

	26	25	24	23	22	21	20	Dest													
	OS	P			1	0															
Immediate → OLC	19	18	17	16	15	14	13							6	1						
	1000							100									Immediate				
Data Latch → OLC	19	18	17	16	15	14	13														
	1000							010													
OLC-1 → OLC	19	18	17	16	15	14	13														
	1000							001													
Immediate → ILC	19	18	17	16	15	14	13							7	6	1					
	0100							100									0	Immediate			
∞ → ILC	19	18	17	16	15	14	13							7							
	0100							100									1				
Data Latch → ILC	19	18	17	16	15	14	13														
	0100							010													
Sign-Extended Immediate → Data Latch	19	18	17	16	15	14												1			
	0010				Si	gn	Immediate														
Update Flags	19	18	17	16							12				7	6	1				
	0001										nextA			nextB							

The FleetTwo implementation is likely to have an unarchitected “literal latch” at the on deck (OD) stage, which is loaded with the possibly-extended literal *at the time that the set instruction comes on deck*. This latch is then copied into the data latch when a set Data Latch instruction executes.

The Sign-Extended Immediate instruction copies the Immediate field into the least significant bits of the data latch. All other bits of the data latch are filled with a copy of the bit marked “Sign.”

Each of the nextA and nextB fields has the following structure, and indicates which old flag values should be logically ORed together to produce the new flag value:

6	5	4	3	2	1
A	\bar{A}	B	\bar{B}	C	\bar{C}

Each bit corresponds to one possible input; all inputs whose bits are set are ORed together, and the resulting value is assigned to the flag. Note that if none of the bits are set, the value assigned is zero. Note also that it is possible to produce a 1 by ORing any flag with its complement, and that set Flags can be used to create a nop (no-op) by setting each flag to itself.

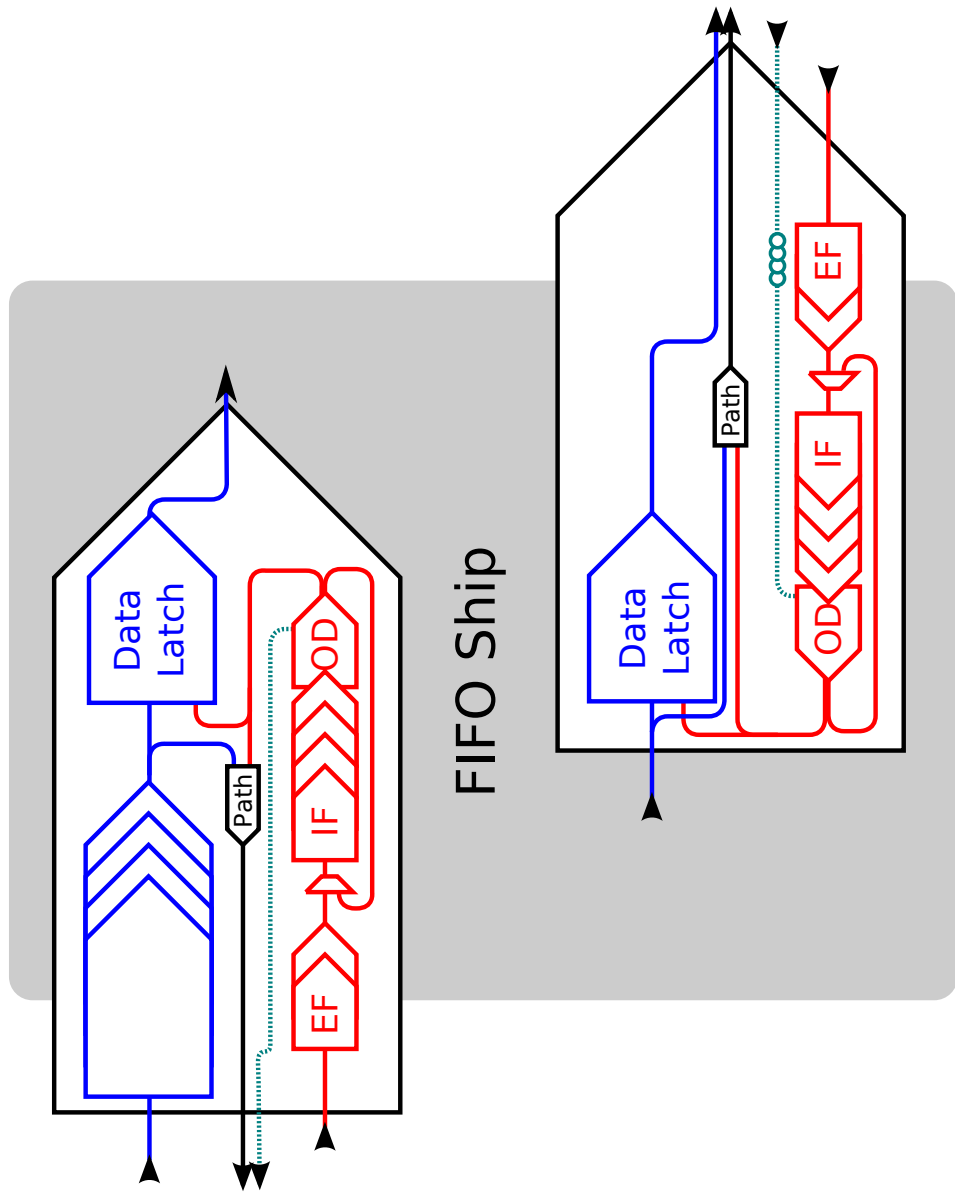

Input Dock

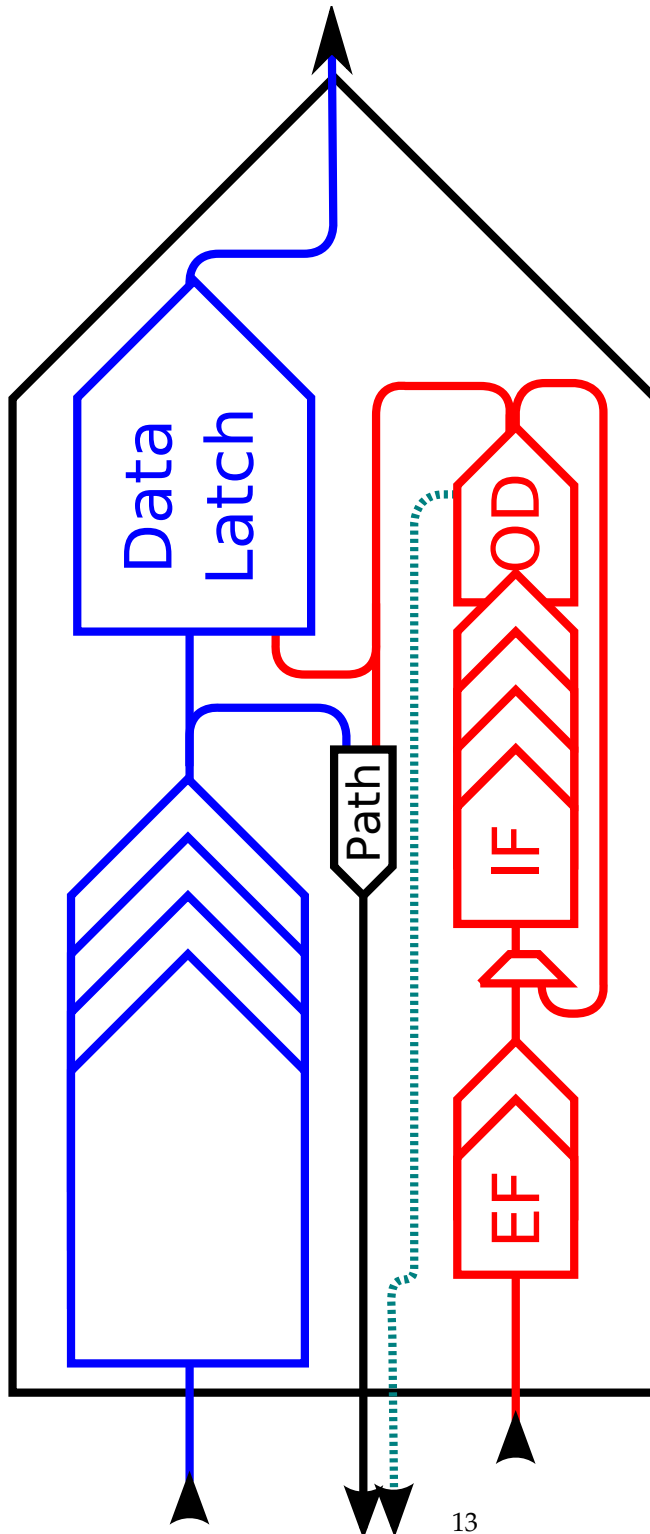

Output Dock

